

CX D-SERIES

CX85D SR

GENERAL DIMENSIONS

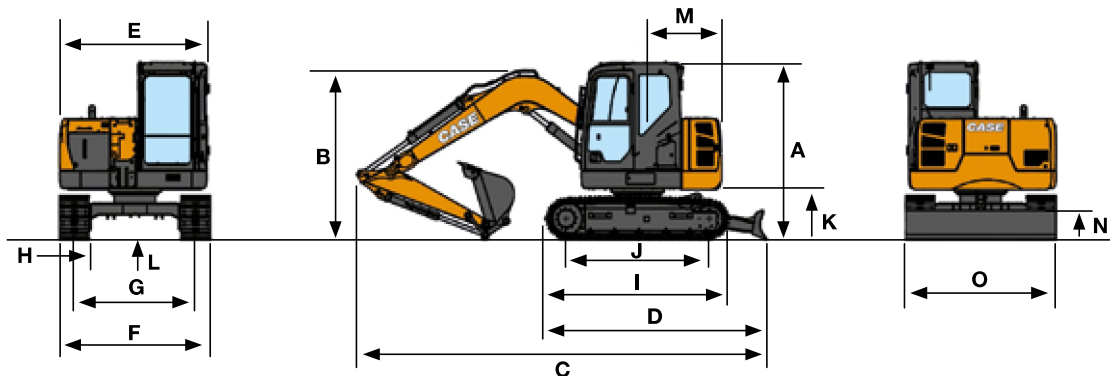

		MONOBOOM Arm 1.69 m	MONOBOOM Arm 2.19 m	OFFSET BOOM Arm 1.75 m	OFFSET BOOM Arm 2.10 m
A	Cab height	mm	2720	2720	2860
B	Overall height (with attachment)	mm	2720	2860	2860
C	Overall length (with attachment)	mm	6310	6340	6310
D	Overall length (without attachment)	mm	3410	3410	3410
E	Upper structure overall width	mm	2270	2270	2270
F	Undercarriage overall width	mm	2320	2320	2320
G	Track gauge	mm	1870	1870	1870
H	Width of standard shoe	mm	450	450	450
I	Crawler overall length	mm	2845	2845	2845
J	Wheel base (Center to center of wheels)	mm	2210	2210	2210
K	Clearance height under upper structure	mm	750	750	750
L	Minimum ground clearance	mm	360	360	360
M	Swing (rear end) radius	mm	1290	1290	1290
N	Blade height	mm	450	450	450
O	Blade width	mm	2320	2320	2320

DIGGING PERFORMANCE

		MONOBOOM Arm 1.69 m	MONOBOOM Arm 2.19 m
Arm digging force	kN	39.5	33.8
Bucket digging force	kN	56.9	56.9
A	Maximum reach	mm	6410
B	Max. digging depth	mm	4130
C	Max. digging height	mm	7370
D	Max. dumping height	mm	5280
E	Max dozer blade lift above ground	mm	440
F	Max dozer drop below ground	mm	280

		OFFSET BOOM Arm 1.75 m	OFFSET BOOM Arm 2.10 m
Arm digging force	kN	39.4	34.7
Bucket digging force	kN	56.9	56.9
A	Maximum reach	mm	6500
B	Max. digging depth	mm	4250
C	Max. digging height	mm	7380
D	Max. dumping height	mm	5310
E	Max dozer blade lift above ground	mm	440
F	Max dozer drop below ground	mm	280
	Boom offset (L.H.)	mm	1100
	Boom offset (R.H.)	mm	1000

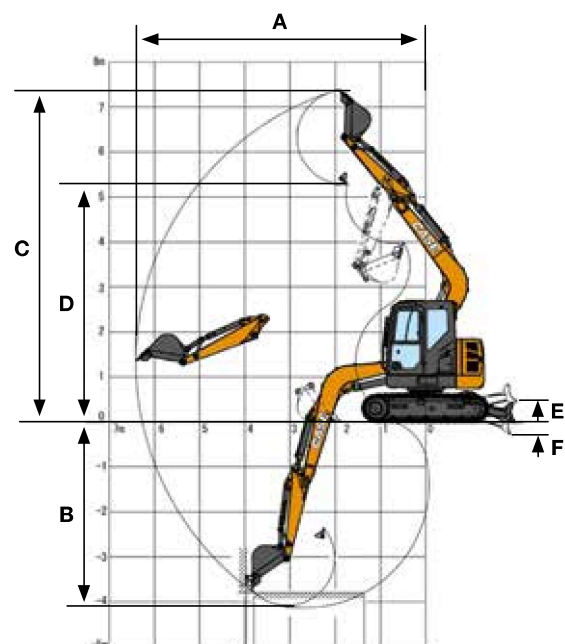

LIFTING CAPACITY

CX85D SR OFFSET BOOM

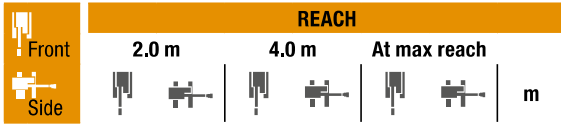

STD ARM / BLADE DOWN

1.75 m length, 450 mm shoes. Max reach 5.45 m

6.0 m					2250*	2250*	2.72
4.0 m	2590*	2590*	1930*	1930*	1850*	1470	4.73
2.0 m			2310*	1770	1820*	1090	5.4
0 m	2180*	2180*	2540*	1560	1860*	1050	5.28
-2.0 m	3550*	3550*	2040*	1550	1830*	1410	4.29

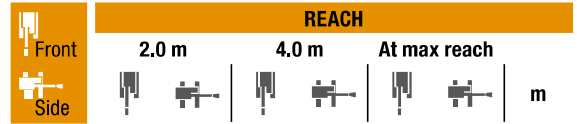

STD ARM / BLADE UP

1.75 m length, 450 mm shoes. Max reach 5.45 m

6.0 m					2250*	2250*	2.72
4.0 m	2590*	2590*	1930*	1910	1540	1410	4.73
2.0 m			1870	1690	1150	1040	5.4
0 m	2180*	2180*	1660	1480	1110	1000	5.28
-2.0 m	3550*	3550*	1640	1470	1500	1340	4.29

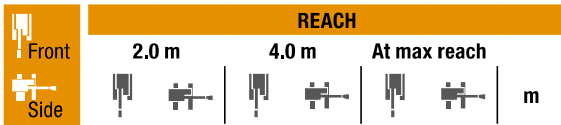

LONG ARM / BLADE DOWN

2.10 m length, 450 mm shoes. Max reach 5.74 m

6.0 m					1910*	1910*	3.28
4.0 m			1780*	1780*	1680*	1310	5.07
2.0 m	3520*	3520*	2190*	1790	1680*	1000	5.7
0 m	2420*	2420*	2500*	1550	1730*	950	5.58
-2.0 m	3940*	3940*	2180*	1500	1760*	1220	4.66

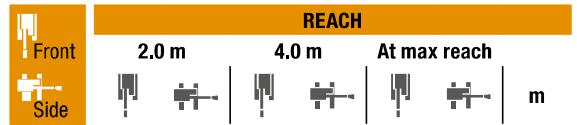

LONG ARM / BLADE UP

2.10 m length, 450 mm shoes. Max reach 5.74 m

6.0 m					1910*	1910*	3.28
4.0 m			1780*	1780*	1380	1260	5.07
2.0 m	3520*	3520*	1900	1710	1050	950	5.7
0 m	2420*	2420*	1650	1470	1010	910	5.58
-2.0 m	3940*	3940*	1600	1420	1290	1160	4.66

LIFTING CAPACITY

CX85D SR MONOBOOM

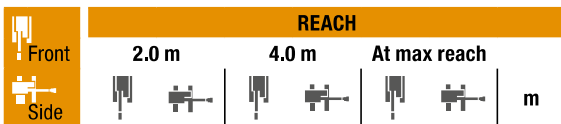

STD ARM / BLADE DOWN

1.69 m length, 450 mm shoes. Max reach 5.36 m

6.0 m					2380*	2380*	2.55
4.0 m			2120*	2030	1780*	1580	4.64
2.0 m			2540*	1900	1800*	1230	5.32
0 m			2810*	1770	2080*	1230	5.19
-2.0 m	3980*	3980*	2180*	1770	2000	1670	4.18

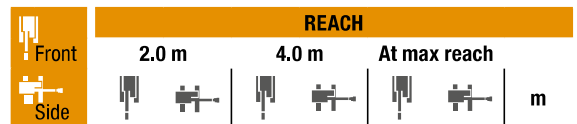

STD ARM / BLADE UP

1.69 m length, 450 mm shoes. Max reach 5.36 m

6.0 m					2380*	2380*	2.55
4.0 m			2120*	1950	1660	1520	4.64
2.0 m			2000	1820	1290	1180	5.32
0 m			1870	1700	1290	1180	5.19
-2.0 m	3980*	3980*	1860	1690	1760	1600	4.18

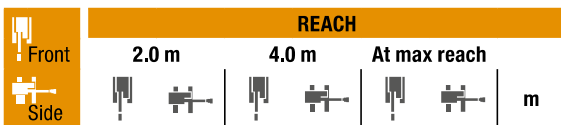

LONG ARM / BLADE DOWN

2.19 m length, 450 mm shoes. Max reach 5.84 m

6.0 m					1780*	1780*	3.45
4.0 m			1870*	1870*	1440*	1340	5.18
2.0 m			2350*	1930	1440*	1090	5.8
0 m			2770*	1770	1680*	1080	5.68
-2.0 m	4620*	4620*	2460*	1730	1880*	1360	4.78

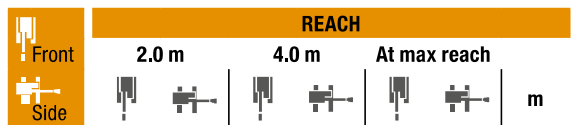

LONG ARM / BLADE UP

2.19 m length, 450 mm shoes. Max reach 5.84 m

6.0 m					1780*	1780*	3.45
4.0 m			1870*	1870*	1400	1290	5.18
2.0 m			2030	1850	1130	1040	5.8
0 m			1870	1700	1130	1030	5.68
-2.0 m	4620*	4620*	1830	1660	1430	1310	4.78

* The above loads (kg) are compliant to the ISO standards and refer to the excavator equipped without bucket. The indicated loads are no more than 87% of hydraulic system lift capacity or 75% of static tipping load. Values marked with an asterisk (*) are limited by the hydraulic lifting capacity.